

# STRONGER THAN EVER KODIAK



## MEET KODIAK GEN 2

The next evolution in scrap handling.

- Built by experts. Proven in the field.
- Engineered from 50+ years of experience in solid waste, oil & gas, and heavy-duty environments.

**POWER. RELIABILITY. DURABILITY.**

That's KODIAK.

Stronger Than Ever.

# BUILT FROM DECADES OF PROVEN PERFORMANCE.



The Kodiak Gen 2 delivers unmatched power, efficiency, and durability for modern scrap operations.

## POWER THAT PERFORMS

- CAT C4.4 192 HP Turbo Diesel
- 4000 PSI hydraulic system
- Armored wear liners

## BUILT FOR SPEED

- Automatic cycles
- Faster cycles with hydraulic regeneration
- Up to 150 bales/day

## SMARTER CONTROL & DESIGN

- Ethernet control system
- Smart sensors & diagnostics
- Touchscreen HMI
- Full-function crane hydraulics

## SERVICE & SAFETY

- Easy access maintenance
- Service platforms
- HVAC cab
- Bluetooth audio

## SPECIFICATIONS

- Bale: 40" x 24"
- Diesel: 90 gal
- Hydraulic: 400 gal
- Boom: ~25 ft reach

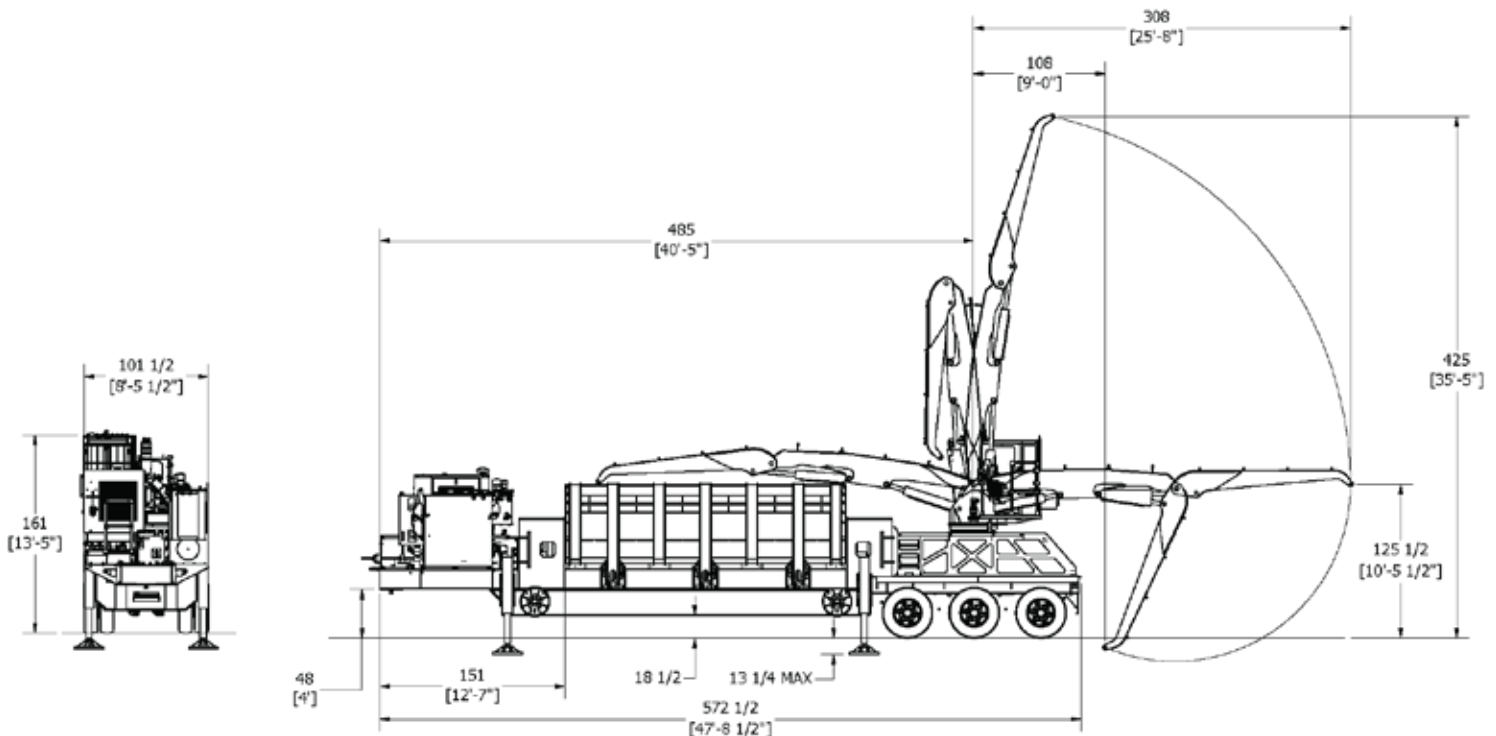

## THE NEXT GENERATION OF STRENGTH

Speed. Safety. Modernization. Serviceability.

The Kodiak Gen 2 is a stronger evolution of a proven legacy.